

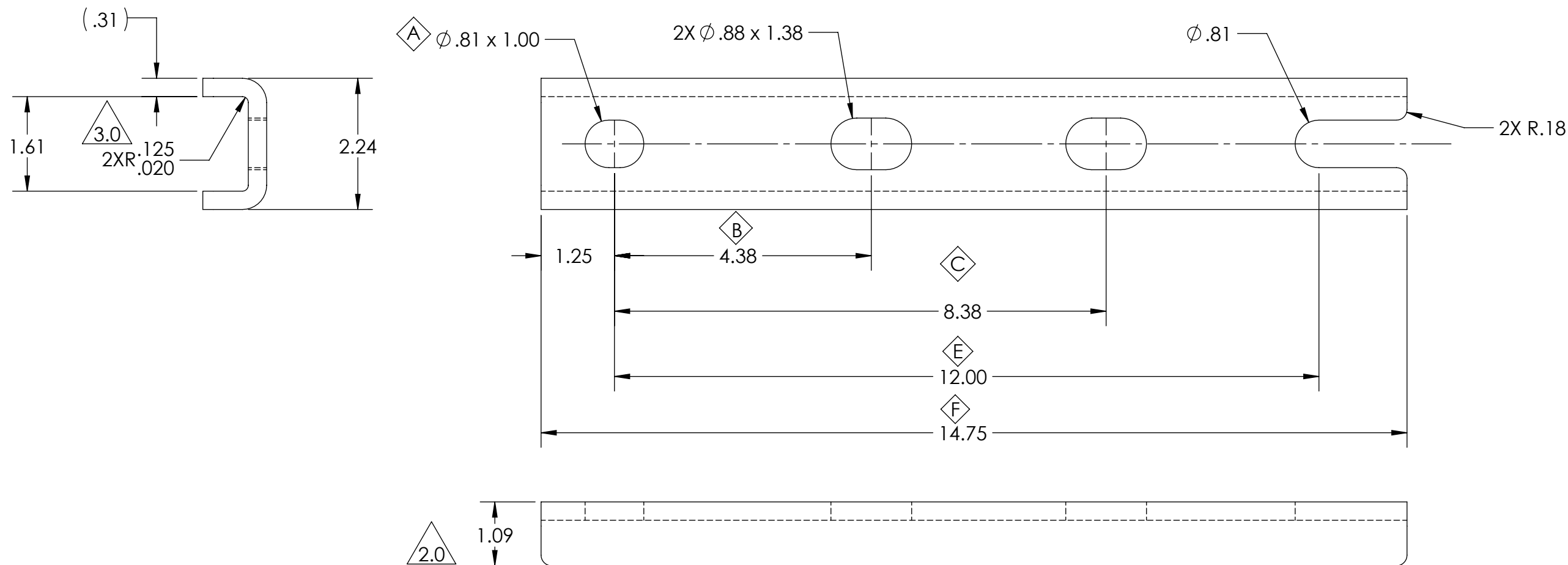

REVISIONS				
REV.	DESCRIPTION	DATE	INITIALS	ECO
1.0	DELETED SLOT	9/25/2019	RJS	
2.0	REDUCED OVERALL HEIGHT FROM 1.19 TO 1.09. INCREASED INSIDE BEND RADIUS FROM R.06 TO R.10	2019-10-21	AJH	
3.0	UPDATE INSIDE RADIUS DIMENSIONS/TOLERANCE	2020-09-04	AJH	4954



- NOTES:
 1. BREAK ALL EDGES UNLESS OTHERWISE NOTED
 2. DIMENSIONS ON PRINT ARE AFTER THE GALVANIZATION PROCESS
 3. TO BE GALVANIZED IN ACCORDANCE WITH ASTM A123/A123M-12 OR ASTM A153/A153M-09
 4. A DIAMOND SYMBOL (\diamond) DENOTES A KEY PRODUCT CHARACTERISTIC

<p>-----UNLESS OTHERWISE SPECIFIED----- DIMENSIONS ARE IN INCHES INTERPRET DIM AND TOL PER ASME Y14.5-2009 ANGULAR: MACH $\pm 2^\circ$ BEND $\pm 2^\circ$ TWO PLACE DECIMAL ± 0.02 THREE PLACE DECIMAL ± 0.005</p>	STATE: RELEASED 2020-09-04	 <p>1421 SECOND AVE NW STEWARTVILLE, MN 55976 (800) 533-1680 www.geotekinc.com</p>
	DRAWN: RJS 2019-09-05 CHECKED: BMR 2020-09-04 APPROVED: AJH 2020-09-04 MATERIAL: ASTM A36 Steel FINISH: GALVANIZED - SEE NOTE REPLACES:	
<p>PROPRIETARY AND CONFIDENTIAL THE INFORMATION CONTAINED IN THIS DRAWING IS THE SOLE PROPERTY OF GEOTEK. ANY REPRODUCTION IN PART OR AS A WHOLE WITHOUT THE WRITTEN PERMISSION OF GEOTEK IS PROHIBITED.</p>	THIRD ANGLE PROJECTION 	SIZE: DWG. NO. B BK-0289 SCALE: 1:2 WEIGHT: 4.28 LBS
		REV: 3.0 SHEET 1 OF 2

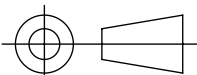
REVISIONS				
ECO	REV.	DESCRIPTION	DATE	INITIALS
	1.0	MATCH REVISION LEVEL OF PART DRAWING	9/25/2019	RJS
	2.0	SEE SHEET 1	10/21/2019	AJH
	3.0	SEE SHEET 1	09/04/2020	AJH

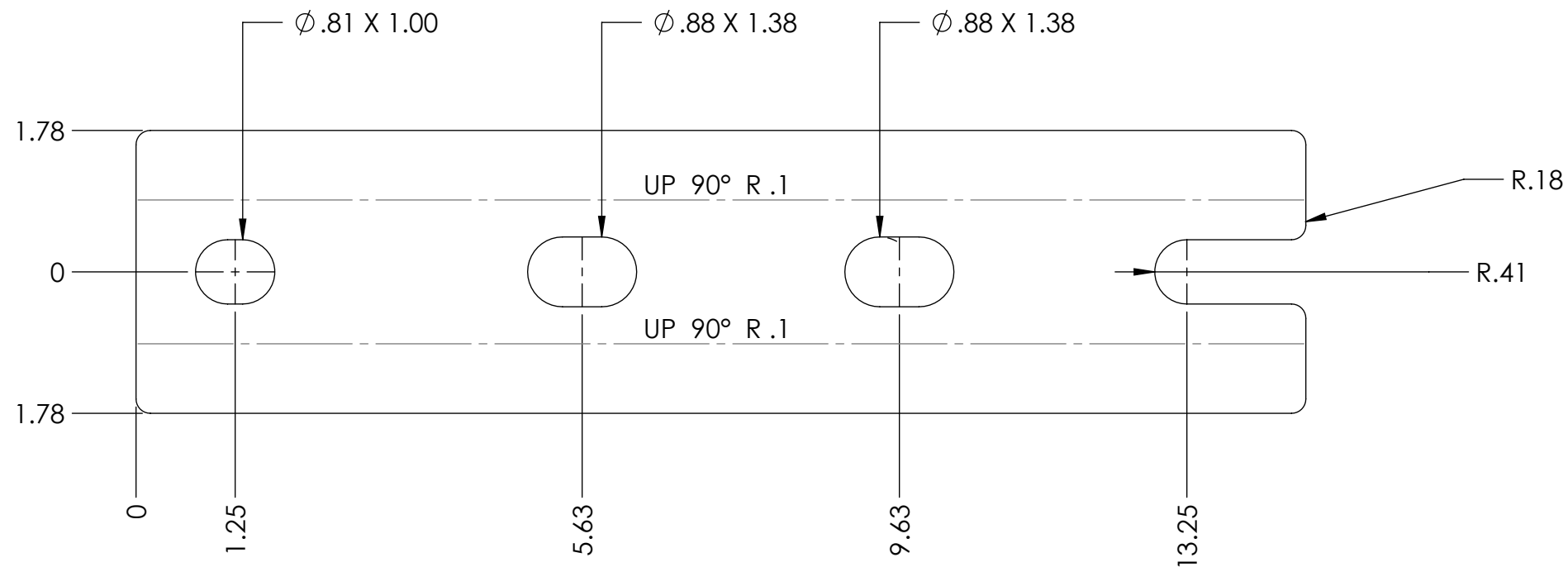

NOTES:
1. FLAT LAYOUT IS USED AS REFERENCE ONLY WITH A NOMINAL R.10 INSIDE RADIUS

-----UNLESS OTHERWISE SPECIFIED-----
DIMENSIONS ARE IN INCHES
INTERPRET DIM AND TOL PER ASME Y14.5-2009
ANGULAR: MACH ±2°
BEND ±2°
TWO PLACE DECIMAL ±0.02
THREE PLACE DECIMAL ±0.005

PROPRIETARY AND CONFIDENTIAL
THE INFORMATION CONTAINED IN THIS DRAWING IS
THE SOLE PROPERTY OF GEOTEK. ANY REPRODUCTION
IN PART OR AS A WHOLE WITHOUT THE WRITTEN
PERMISSION OF GEOTEK IS PROHIBITED.

STATE: RELEASED 2020-09-04
DRAWN: RJS 2019-09-05
CHECKED: BMR 2020-09-04
APPROVED: AJH 2020-09-04
MATERIAL:
ASTM A36 Steel
FINISH:
GALVANIZED - SEE NOTE
REPLACES:
-

THIRD ANGLE PROJECTION

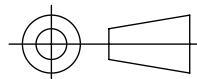

GEOTEK
A Whole New World of Composites
1421 SECOND AVE NW
STEWARTVILLE, MN 55976
(800) 533-1680
www.geotekinc.com

DESCRIPTION:
BRACKET, ADAPTER

SIZE: DWG. NO. **B BK-0289** REV: **3.0**
SCALE: 1:2 WEIGHT: 4.28 LBS SHEET 2 OF 2